

AM Transmitter

AM transmitter takes the audio signal as an input and delivers amplitude modulated wave to the antenna as an output to be transmitted. The block diagram of AM transmitter is shown in the following figure.

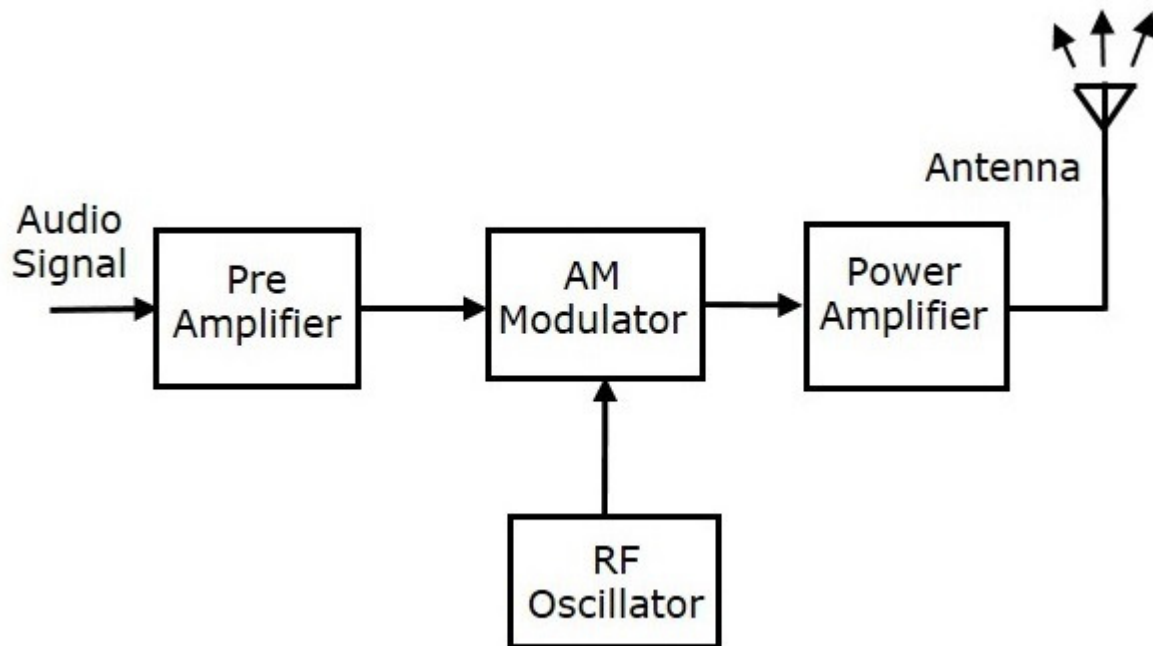

The working of AM transmitter can be explained as follows.

- The audio signal from the output of the microphone is sent to the pre-amplifier, which boosts the level of the modulating signal.
- The RF oscillator generates the carrier signal.
- Both the modulating and the carrier signal is sent to AM modulator.
- Power amplifier is used to increase the power levels of AM wave. This wave is finally passed to the antenna to be transmitted.

FM Transmitter

FM transmitter is the whole unit, which takes the audio signal as an input and delivers FM wave to the antenna as an output to be transmitted. The block diagram of FM transmitter is shown in the following figure.

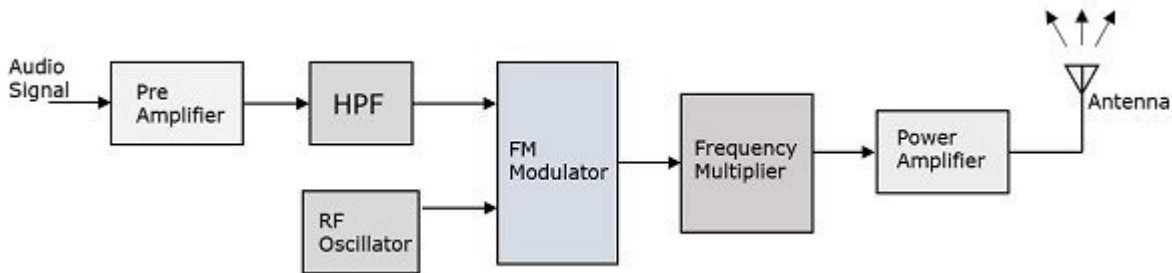

The working of FM transmitter can be explained as follows.

- The audio signal from the output of the microphone is sent to the pre-amplifier, which boosts the level of the modulating signal.
- This signal is then passed to high pass filter, which acts as a pre-emphasis network to filter out the noise and improve the signal to noise ratio.
- This signal is further passed to the FM modulator circuit.
- The oscillator circuit generates a high frequency carrier, which is sent to the modulator along with the modulating signal.
- Several stages of frequency multiplier are used to increase the operating frequency. Even then, the power of the signal is not enough to transmit. Hence, a RF power amplifier is used at the end to increase the power of the modulated signal. This FM modulated output is finally passed to the antenna to be transmitted.

How receivers work^[edit]

See also: [Radio receiver design](#)

A radio receiver is connected to an [antenna](#) which converts some of the energy from the incoming radio wave into a tiny [radio frequency AC voltage](#) which is applied to the receiver's input. An antenna typically consists of an arrangement of metal conductors. The oscillating [electric](#) and [magnetic fields](#) of the radio wave push the [electrons](#) in the antenna back and forth, creating an oscillating voltage.

The antenna may be enclosed inside the receiver's case, as with the [ferrite loop antennas](#) of [AM radios](#) and the flat [inverted F antenna](#) of cell phones; attached to the outside of the receiver, as with [whip antennas](#) used on [FM radios](#), or mounted separately and connected to the receiver by a cable, as with rooftop [television antennas](#) and [satellite dishes](#).

Filtering, amplification, and demodulation^[edit]

Practical radio receivers perform three basic functions on the signal from the antenna: [filtering](#), [amplification](#), and [demodulation](#).^[5]

- **Bandpass filtering:** Radio waves from many transmitters pass through the air simultaneously without interfering with each other. These can be separated in the receiver because they have different [frequencies](#); that is, the radio wave from each transmitter oscillates at a different rate.

To separate out the desired radio signal, the [bandpass filter](#) allows the frequency of the desired radio transmission to pass through, and blocks signals at all other frequencies.

The bandpass filter consists of one or more [resonant circuits](#) (tuned circuits). The resonant circuit is connected between the antenna input and ground. When the incoming radio signal is at the resonant frequency, the resonant circuit has high impedance and the radio signal from the desired station is passed on to the following stages of the receiver. At all other frequencies the resonant circuit has low impedance, so signals at these frequencies are conducted to ground.

- - **Bandwidth and selectivity:** See graphs. The information ([modulation](#)) in a radio transmission is contained in two narrow bands of frequencies called [sidebands](#) (SB) on either side of the [carrier](#) frequency (C), so the filter has to pass a band of frequencies, not just a single frequency. The band of frequencies received by the receiver is called its [passband](#) (PB), and the width of the passband in [kilohertz](#) is called the [bandwidth](#) (BW). The bandwidth of the filter must be wide enough to allow the sidebands through without distortion, but narrow enough to block any interfering transmissions on adjacent frequencies (such as S2 in the diagram). The ability of the receiver to reject unwanted radio stations near in frequency to the desired station is an important parameter called [selectivity](#) determined by the filter. In modern receivers [quartz crystal](#), [ceramic resonator](#), or [surface acoustic wave](#) (SAW) filters are often used which have sharper selectivity compared to networks of capacitor-inductor tuned circuits.
 - **Tuning:** To select a particular station the radio is "tuned" to the frequency of the desired transmitter. The radio has a dial or digital display showing the frequency it is tuned to. *Tuning* is adjusting the frequency of the receiver's passband to the frequency of the desired radio transmitter. Turning the tuning knob changes the [resonant frequency](#) of the [tuned circuit](#). When the resonant frequency is equal to the radio transmitter's frequency the tuned circuit oscillates in sympathy, passing the signal on to the rest of the receiver.

The [frequency spectrum](#) of a typical radio signal from an AM or FM radio transmitter. It consists of a component (C) at the [carrier wave](#) frequency f_c , with the modulation contained in narrow frequency bands called [sidebands](#) (SB) just above and below the carrier.

(right graph) How the bandpass filter selects a single radio signal S1 from all the radio signals received by the antenna. From top, the graphs show the voltage from the antenna applied to the filter V_{in} , the [transfer function](#) of the filter T , and the voltage at the output of the filter V_{out} as a function of frequency f . The transfer function T is the amount of signal that gets through the filter at each frequency:

- **Amplification:** The power of the radio waves picked up by a receiving antenna decreases with the square of its distance from the transmitting antenna. Even with the powerful transmitters used in radio broadcasting stations, if the receiver is more than a few miles from the transmitter the power intercepted by the receiver's antenna is very small, perhaps as low

as [picowatts](#). To increase the power of the recovered signal, an [amplifier](#) circuit uses electric power from batteries or the wall plug to increase the [amplitude](#) (voltage or current) of the signal. In most modern receivers, the electronic components which do the actual amplifying are [transistors](#).

Receivers usually have several stages of amplification: the radio signal from the bandpass filter is amplified to make it powerful enough to drive the demodulator, then the audio signal from the demodulator is amplified to make it powerful enough to operate the speaker. The degree of amplification of a radio receiver is measured by a parameter called its [sensitivity](#), which is the minimum signal strength of a station at the antenna, measured in [microvolts](#), necessary to receive the signal clearly, with a certain [signal-to-noise ratio](#). Since it is easy to amplify a signal to any desired degree, the limit to the sensitivity of many modern receivers is not the degree of amplification but random [electronic noise](#) present in the circuit, which can drown out a weak radio signal.

- **Demodulation:** After the radio signal is filtered and amplified, the receiver must extract the information-bearing [modulation](#) signal from the modulated radio frequency [carrier wave](#). This is done by a circuit called a [demodulator](#) ([detector](#)). Each type of modulation requires a different type of demodulator
- an AM receiver that receives an ([amplitude modulated](#)) radio signal uses an AM demodulator
- an FM receiver that receives a [frequency modulated](#) signal uses an FM demodulator
- an FSK receiver which receives [frequency shift keying](#) (used to transmit digital data in wireless devices) uses an FSK demodulator

Many other types of modulation are also used for specialized purposes.

The modulation signal output by the demodulator is usually amplified to increase its strength, then the information is converted back to a human-usable form by some type of [transducer](#). An [audio signal](#), representing sound, as in a broadcast radio, is converted to [sound waves](#) by an [earphone](#) or [loudspeaker](#). A [video signal](#), representing moving images, as in a [television receiver](#), is converted to light by a [display](#). [Digital data](#), as in a [wireless modem](#), is applied as input to a [computer](#) or [microprocessor](#), which interacts with human users.

AM demodulation^{[[edit](#)]}

Main article: [Envelope detector](#)

How an envelope detector works

The easiest type of demodulation to understand is AM demodulation, used in [AM radios](#) to recover the [audio](#) modulation signal, which represents sound and is converted to [sound waves](#) by the radio's [speaker](#). It is accomplished by a circuit called an [envelope detector](#) (see *circuit*), consisting of a [diode](#) (*D*) with a bypass [capacitor](#) (*C*) across its output. See graphs. The [amplitude modulated](#) radio signal from the tuned circuit is shown at (*A*). The rapid oscillations are the [radio frequency carrier wave](#). The [audio signal](#) (the sound) is contained in the slow variations ([modulation](#)) of the [amplitude](#) (size) of the waves. If it was

applied directly to the speaker, this signal cannot be converted to sound, because the audio excursions are the same on both sides of the axis, averaging out to zero, which would result in no net motion of the speaker's diaphragm. (B) When this signal is applied as input V_i to the detector, the diode (D) conducts current in one direction but not in the opposite direction, thus allowing through pulses of current on only one side of the signal. In other words, it rectifies the AC current to a pulsing DC current. The resulting voltage V_o applied to the load R_L no longer averages zero; its peak value is proportional to the audio signal. (C) The bypass capacitor (C) is charged up by the current pulses from the diode, and its voltage follows the peaks of the pulses, the envelope of the audio wave. It performs a smoothing (low pass filtering) function, removing the radio frequency carrier pulses, leaving the low frequency audio signal to pass through the load R_L . The audio signal is amplified and applied to earphones or a speaker.

Tuned radio frequency (TRF) receiver^[edit]

Main article: [Tuned radio frequency receiver](#)

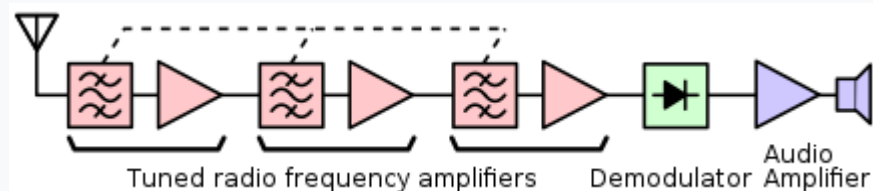

Block diagram of a tuned radio frequency receiver. To achieve enough selectivity to reject stations on adjacent frequencies, multiple cascaded bandpass filter stages had to be used. The dotted line indicates that the bandpass filters must be tuned together.

In the simplest type of radio receiver, called a tuned radio frequency (TRF) receiver, the three functions above are performed consecutively:^[6] (1) the mix of radio signals from the antenna is filtered to extract the signal of the desired transmitter; (2) this oscillating voltage is sent through a radio frequency (RF) amplifier to increase its strength to a level sufficient to drive the demodulator; (3) the demodulator recovers the modulation signal (which in broadcast receivers is an audio signal, a voltage oscillating at an audio frequency rate representing the sound waves) from the modulated radio carrier wave; (4) the modulation signal is amplified further in an audio amplifier, then is applied to a loudspeaker or earphone to convert it to sound waves.

Although the TRF receiver is used in a few applications, it has practical disadvantages which make it inferior to the superheterodyne receiver below, which is used in most applications.^[6] The drawbacks stem from the fact that in the TRF the filtering, amplification, and demodulation are done at the high frequency of the incoming radio signal. The bandwidth of a filter increases with its center frequency, so as the TRF receiver is tuned to different frequencies its bandwidth varies. Most important, the increasing

congestion of the [radio spectrum](#) requires that radio channels be spaced very close together in frequency. It is extremely difficult to build filters operating at radio frequencies that have a narrow enough bandwidth to separate closely spaced radio stations. TRF receivers typically must have many cascaded tuning stages to achieve adequate selectivity. The [Advantages](#) section below describes how the superheterodyne receiver overcomes these problems.

The superheterodyne design [\[edit\]](#)

Main article: [Superheterodyne receiver](#)

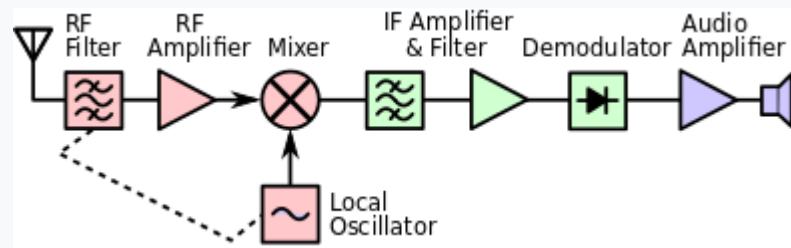

Block diagram of a superheterodyne receiver. The dotted line indicates that the RF filter and local oscillator must be tuned in tandem.

The [superheterodyne](#) receiver, invented in 1918 by [Edwin Armstrong](#)^[7] is the design used in almost all modern receivers^{[8][6][9][10]} except a few specialized applications.

In the superheterodyne, the radio frequency signal from the antenna is shifted down to a lower "[intermediate frequency](#)" (IF), before it is processed.^{[1][1][2][13][14]} The incoming radio frequency signal from the antenna is mixed with an unmodulated signal generated by a [local oscillator](#) (LO) in the receiver. The mixing is done in a nonlinear circuit called the "[mixer](#)". The result at the output of the mixer is a [heterodyne](#) or beat frequency at the difference between these two frequencies. The process is similar to the way two musical notes at different frequencies played together produce a [beat note](#). This lower frequency is called the [intermediate frequency](#) (IF). The IF signal also has all the information that was present in the original RF signal. The IF signal passes through filter and amplifier stages,^[9] then is [demodulated](#) in a detector, recovering the original modulation.

The receiver is easy to tune; to receive a different frequency it is only necessary to change the local oscillator frequency. The stages of the

receiver after the mixer operates at the fixed intermediate frequency (IF) so the IF bandpass filter does not have to be adjusted to different frequencies. The fixed frequency allows modern receivers to use sophisticated [quartz crystal](#), [ceramic resonator](#), or [surface acoustic wave](#) (SAW) IF filters that have very high [Q factors](#), to improve selectivity.

The RF filter on the front end of the receiver is needed to prevent interference from any radio signals at the [image frequency](#). Without an input filter the receiver can receive incoming RF signals at two different frequencies,^{[15][10][14][16]} The receiver can be designed to receive on either of these two frequencies; if the receiver is designed to receive on one, any other radio station or radio noise on the other frequency may pass through and interfere with the desired signal. A single tunable RF filter stage rejects the image frequency; since these are relatively far from the desired frequency, a simple filter provides adequate rejection. Rejection of interfering signals much closer in frequency to the desired signal is handled by the multiple sharply-tuned stages of the intermediate frequency amplifiers, which do not need to change their tuning.^[10] This filter does not need great selectivity, but as the receiver is tuned to different frequencies it must "track" in tandem with the local oscillator. The RF filter also serves to limit the bandwidth applied to the RF amplifier, preventing it from being overloaded by strong out-of-band signals.

Block diagram of a dual-conversion superheterodyne receiver

To achieve both good image rejection and selectivity, many modern superhet receivers use two intermediate frequencies; this is called a *dual-conversion* or *double-conversion* superheterodyne.^[6] The incoming RF signal is first mixed with one local oscillator signal in the first mixer to convert it to a high IF frequency, to allow efficient filtering out of the image frequency, then this first IF is mixed with a second local oscillator signal in a second mixer to convert it to a low IF frequency for good bandpass filtering. Some receivers even use triple-conversion.

At the cost of the extra stages, the superheterodyne receiver provides the advantage of greater selectivity than can be achieved with a TRF design. Where very high frequencies are in use, only the initial stage of the receiver needs to operate at the highest frequencies; the remaining stages can provide much of the receiver gain at lower frequencies which may be easier to manage. Tuning is simplified compared to a multi-stage TRF design, and only two stages need to track over the tuning range. The total amplification of the receiver is divided between three amplifiers at different frequencies; the RF, IF, and audio amplifier. This reduces problems with feedback and [parasitic oscillations](#) that are encountered in receivers where most of the amplifier stages operate at the same frequency, as in the TRF receiver.^[11]

The most important advantage is that better [selectivity](#) can be achieved by doing the filtering at the lower intermediate frequency.^{[6][9][11]} One of the most important parameters of a receiver is its [bandwidth](#), the band of frequencies it accepts. In order to reject nearby interfering stations or noise, a narrow bandwidth is required. In all known filtering techniques, the bandwidth of the filter increases in proportion with the frequency, so by performing the

filtering at the lower [17], rather than the frequency of the original radio

signal [9], a narrower bandwidth can be achieved. Modern FM and television broadcasting, cellphones and other communications services, with their narrow channel widths, would be impossible without the superheterodyne.^[9]

Automatic gain control (AGC)[edit]

Main article: [Automatic gain control](#)

The [signal strength](#) ([amplitude](#)) of the radio signal from a receiver's antenna varies drastically, by orders of magnitude, depending on how far away the radio transmitter is, how powerful it is, and [propagation](#) conditions along the path of the radio waves.^[17] The strength of the signal received from a given transmitter varies with time due to changing propagation conditions of the path through which the radio wave passes, such as [multipath interference](#); this is called *fading*.^{[17][6]} In an AM receiver the amplitude of the audio signal from the detector, and the sound volume, is proportional to the amplitude of the radio signal, so fading causes variations in the volume. In addition as the receiver is tuned between strong and weak stations, the volume of the sound from the speaker would vary drastically. Without an automatic system to handle it, in an AM receiver constant adjustment of the volume control would be required.

With other types of modulation like FM or FSK the amplitude of the modulation does not vary with the radio signal strength, but in all types the demodulator requires a certain range of signal amplitude to operate properly.^{[6][18]} Insufficient signal amplitude will cause an increase of noise in the demodulator, while excessive signal amplitude will cause amplifier stages to overload (saturate), causing distortion (clipping) of the signal.

Therefore, almost all modern receivers include a [feedback control system](#) which monitors the *average* level of the radio signal at the detector, and adjusts the [gain](#) of the amplifiers to give the optimum signal level for demodulation.^{[6][18][17]} This is called [automatic gain control](#) (AGC). AGC can be compared to the [dark adaptation](#) mechanism in the [human eye](#); on entering a dark room the gain of the eye is increased by the iris opening.^[17] In its simplest form an AGC system consists of a [rectifier](#) which converts the RF signal to a varying DC level, a [lowpass filter](#) to smooth the variations and produce an average level.^[18] This is applied as a control signal to an earlier amplifier stage, to control its gain. In a superheterodyne receiver AGC is usually applied to the [IF amplifier](#), and there may be a second AGC loop to control the gain of the RF amplifier to prevent it from overloading, too.

In certain receiver designs such as modern digital receivers, a related problem is [DC offset](#) of the signal. This is corrected by a similar feedback system.